

by GABRIEL TEIXIDÓ ”

ON

ZON
INTERNATIONAL

levira®

“IT’S ALL ABOUT MOVEMENT EVERY MOVEMENT IS AN OPTION, EVERY OPTION, A CONNECTION’ OF MOVEMENTS!”

1

A linha ON herda da linha OXO um sistema completo que permite combinar elementos comuns. Montar, trocar e modificar configurações é uma tarefa fácil com o sistema de montagem por clips. ON dispõe de um programa completo: armários, estantes, biombo separadores e uma vasta gama de acessórios fáceis de mover ou de trocar de lugar. ON dispõe ainda de dois tipos de pernas: fechado “O” e aberto “N” ambos com a possibilidade de regulação em altura. ON permite múltiplas combinações de cores, estruturas brancas, pretas ou metalizadas, tampos igualmente em branco e preto, madeira de carvalho e vidro.

ON inherits OXO’s complete system allowing to combine common parts; assembling, changing and reconfiguring workstations is easy due to its click assembling scheme. ON is a complete system, storage cabinets, book shelves, partitions and a large range of accessories easy to move or change. Furthermore ON has two different types of legs, closed “O” and open “N” both with optional height adjustment. ON allows multiple chromatic combinations, structures in white, black or metallic grey and tops in white, black, natural oak veneer or glass.

ON hereda el completo sistema de la línea OXO permitiendo combinar elementos comunes, montar, cambiar modificar configuraciones es fácil con su sistema de montaje clipado. ON es un completo programa, armarios, librerías, biombos separadores y una amplia gama de accesorios fáciles de mover o cambiar su ubicación. ON además dispone de dos tipos de pies, cerrado “O” y abierto “N” ambos con la opción de regulación en altura. ON permite múltiples combinaciones cromáticas, estructuras blancas, negras o metalizadas y sobres en blanco, negro, madera de roble o cristal.

ON hérite le système complet de la collection OXO permettant combiner des éléments communs ; modifier, changer les configurations devient simple avec son système de montage par clips. ON est un programme complet, armoires, meubles à étagères, cloisons et une ample gamme d’accessoires permettant changer ou modifier leur positionnement. ON dispose de deux types de pieds, fermé “O” et ouvert “N” tous deux avec option de régulation en hauteur. ON permet de multiples combinaisons chromatiques, structures blanches, noires ou métallisées et plateaux en blanc, noir, bois chêne ou verre.





o”







levira

10
11

Mesas com perna "O" em branco, com balcão em Carvalho natural e separador frontal em tecido. É uma das possibilidades para as zonas abertas ao público.

Desks with "O" white leg with a natural oak veneer reception counter and a fabric screen, it is one of the possibilities for public areas.

Mesas con pie "O" en blanco con mostrador en roble natural y separador frontal en tela, es una de las posibilidades para zonas abiertas al público.

Tables avec pied "O" en blanc avec banque d'accueil en chêne couleur naturel et panneau frontal en tissu, c'est l'une des possibilités pour les zones ouvertes au public.



N”

O sistema de montagem não podia ser mais simples, com quatro parafusos por mesa e num só CLICK... resultado: estético, simples e limpo. Configuração com perna “N”, estrutura em branco com blocos de gavetas suspensos, módulos, tampos em Carvalho natural, armários e blocos rodados.

The assembling scheme cannot be simpler, only four screws per desk and the rest only with a “CLICK”, the result is a simple and clean look. Configuration with white “N” structure with suspended pedestals, returns, natural oak veneer tops, storage cabinets and pedestal on castors.

El sistema de montaje no puede ser más simple; sólo cuatro tornillos por mesa y el resto sólo con un “CLIK”, resultado: una estética simple y limpia. Configuración con pie “N” y estructura en blanco con bloques de cajones colgados, alas auxiliares puente, sobres en roble natural, armarios y bloque con ruedas.

Le système de montage ne peut être plus simple; seulement quatre vis par table et le reste seulement avec un “CLIK”, résultat : esthétique, simple et propre. Configuration avec pied “N” et structure en blanc avec caissons suspendus, retours, plateaux en chêne couleur naturel, armoires et caisson avec roulettes.







Área de trabalho dupla (1600mm) perna "O" em preto, o segundo nível central com prateleiras em branco, suportes de monitor totalmente reguláveis e tampos em preto. Os armários bicolores em branco e preto são o contraponto crômático.

Double depth working tops (1600mm) black "O" legs, central second level with white shelves, totally adjustable monitor supports and black tops. The bicolor white and black cabinets are the chromatic counterpoint.

Área de trabajo de doble anchura (1600mm) pie "O" en negro, segundo nivel central con bandejas en blanco, soportes de pantalla totalmente regulables y tableros en negro. Los armarios bicolor en blanco y negro son el contrapunto cromático.

Zone de travail double (1600mm) pied "O" en noir, deuxième niveau central avec tablettes en blanc, supports écran totalement réglables et plateaux en noir. Les armoires "Black and White" sont la preuve du contrepoint chromatique.







levira.





260
27N





A linha "ON" cria zonas direccionais ou gabinetes que requerem alguma distinção com mesas de vidro e tubos de aço inox, a sua estrutura à vista transforma-se num elemento estético de grande expressividade.

"ON" has also an answer for managerial areas or a distinguished office with glass top desks and stainless steel support bars, its structure is visible and turns itself into an aesthetic and greatly formal solution.

"ON" resuelve zonas direccionales o despachos que requieren algo distinto con mesas de cristal y tubos en acero inoxidable, su estructura vista se transforma en un elemento estético de gran expresividad formal.

"ON" solutionne les zones de direction qui demandent une certaine distinction; avec des tables en verre et traverses en inox, sa structure visible se transforme en un élément esthétique de grande expression.





N”

A perna “N” em branco, preto ou metalizado e tampo de vidro são mais uma opção da linha “ON” que em conjunto com as restantes alternativas permitem em grandes instalações demarcar hierarquias ou zonas sem perder a imagem ordenada e esteticamente agradável.

White, black or metallic grey “N” legs with a glass top are one option more that “ON” has to offer, together with the rest of the alternatives allow us to create different hierarchy degrees or areas without losing the elegant and organized image.

El pie “N” en blanco, negro o metalizado y sobre de cristal son una opción más de “ON” que junto con el resto de alternativas permiten en grandes instalaciones marcar jerarquías o zonas sin perder una imagen de conjunto ordenada y estéticamente agradable.

Le pied “N” en blanc, noir ou métallisé et plateau en verre sont une option supplémentaire de “ON” qui, avec le reste des alternatives, permettent sur les grandes installations marquer les hiérarchies ou zones sans perdre l’image d’un ensemble ordonné et esthétiquement agréable.

A perna "N" permite criar mesas de reuniões com tampo em vidro, madeira ou estratificado, completando as necessidades das distintas áreas de trabalho. O seu sistema polivalente e flexível possibilita configurações de ângulo em "U" ou fechadas para áreas de reunião em que se requer algo especial.

"N" legs allow to create glass top, veneer or laminate meeting tables, completing the needs of the different working areas. Its flexible and polyvalent system makes it possible to create angular "U" shaped or closed solutions for specific meeting rooms that require a special solution.

El pie "N" permiten crear mesas de reuniones de cristal, madera o estratificado, completando las necesidades de las distintas áreas de trabajo. Su sistema polivalente y flexible hace posible crear configuraciones angulares en "U" o cerradas para salas de reuniones específicas que requieren algo especial.

Le pied "N" permet la création de tables de réunion avec plateau en verre, bois ou stratifié, complétant les besoins des différentes zones de travail. Son système polyvalent et flexible rend possible la création de configurations angulaires en "U" ou fermées pour des salles de réunion spécifiques.

levira

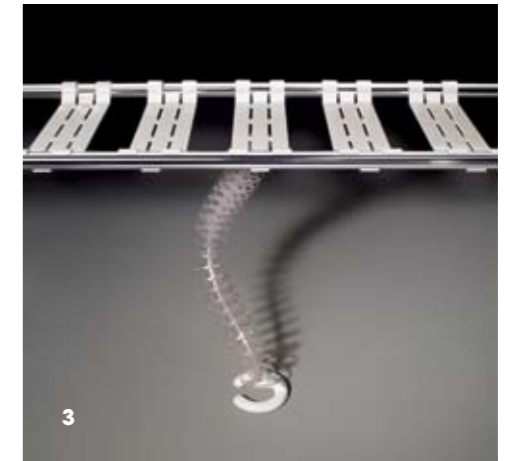













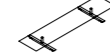

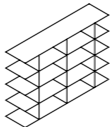
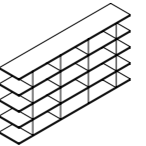

34
35

- 1**
Clip tampo / Top clip / Clip tablero / Clip plateau
- 2**
Clip mesa auxiliar / Return clip / Clip mesa auxiliar / Clip retour
- 3**
Electrificação horizontal e vertical / Horizontal and vertical cable channels /
Electrificación horizontal y vertical / Électrification horizontale et verticale
- 4**
União da mesa ao armário / Table cabinet joint / Unión mesa armario /
Union table-armoire
- 5**
Zona de arquivo entre mesas / Storage units between desks / Contenedor
entre mesas / Rangement entre tables

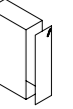

ACCESSÓRIOS / ACCESSORIES / ACCESORIOS / ACCESSOIRES

| | | | | | | | | | | | | | | |
|--|---|---|---|--|---|--|--|--|---|---|---|---|--|---|
| <p>Suporte monitor Monitor holder Soporte pantalla Support écran</p>  | <p>Passagem de cabos Cable management Bandeja pasacables Goulotte pour passage de cables</p>  <p>400 x 120</p> | <p>Suporte CPU CPU holder Soporte CPU Support UC</p>  <p>226 x 435 x 505</p> | <p>Armário aberto Open storage unit Armario abierto Armoire ouvert</p>  <p>800 x 300 x 330</p> | <p>Prateleira Shelf Estante Tablette</p>  <p>1100 x 300 1300 x 300 1500 x 300</p> | <p>Suporte papéis Paper holder Soporte papeles Support papiers</p>  <p>220 x 300 x 198</p>  <p>220 x 300 x 73</p> | <p>Painel em tecido Fabric screen Panel tapizado Panneau tapissé</p>  <p>800x35x345</p>  <p>1100 x 35 x 345</p>  <p>1300 x 35 x 345</p> | <p>Base de apoio do blombo Base panel suelo Screen foot Base d'appui de la cloison</p>  <p>800 x 1500 1000 x 1500</p> | <p>Estante com prateleiras metálicas Shelving unit with metal shelves Estantería con estantes metálicos Meuble à étagères métalliques</p>  <p>1800 x 420 x 1190</p> | <p>Estante com prateleiras em madeira Shelving unit with wooden shelves Estantería con estantes madera Meuble à étagères en bois</p>  <p>1800 x 420 x 1190 2400 x 420 x 1190</p> | <p>Bloco 3 gavetas Three drawers pedestal Bloque con 3 cajones Caisson avec 3 tiroirs</p>  <p>300 x 600 x 630</p>  <p>410 x 579 x 562</p> | <p>Bloco 1 gaveta e gaveta arquivo 1 standard + 1 file drawer pedestal Bloque con 1 cajón y archivo Caisson 1 tiroir et archive</p>  <p>300 x 600 x 630</p>  <p>410 x 579 x 562</p> | <p>Armário com 2 gavetas arquivo Two drawers file unit Armario con 2 cajones archivo Armoire avec 2 tiroirs archive</p>  <p>1000 x 420 x 840</p> | <p>Armário com portas batentes Hanging doors cabinet Armario con puertas batientes Armoire avec portes battantes</p>  <p>800 x 420 x 840 800 x 420 x 1190 800 x 420 x 1540 1000 x 420 x 840 1000 x 420 x 1190</p> | <p>Armário com gavetas e vestário Cabinet with drawers and coat locker Armario con cajones y ropero Armoire avec tiroirs et vestiaire</p>  <p>300 x 800 x 1300</p> |
|--|---|---|---|--|---|--|--|--|---|---|---|---|--|---|

MESAS E ELEMENTOS BÁSICOS / DESKS AND BASIC PARTS / MESAS Y ELEMENTOS BÁSICOS / TABLES ET ÉLÉMENTS DE BASE

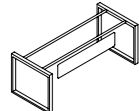
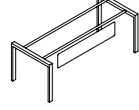
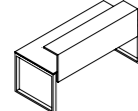
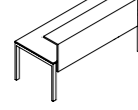
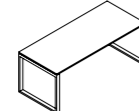
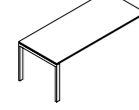
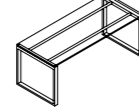
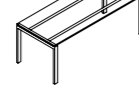
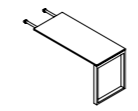
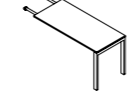
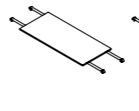
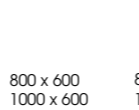
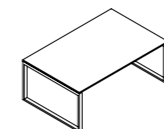
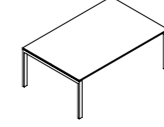
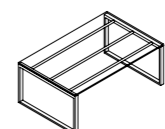
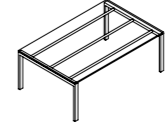
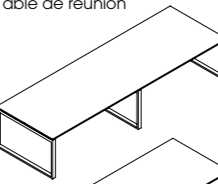
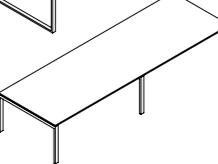
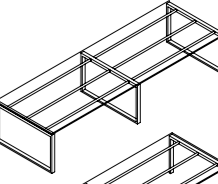
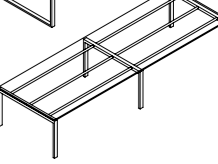
| | | | | | | | | | |
|--|---|---|---|---|---|---|---|---|---|
| <p>Painel Modesty panel Faldón Voile de fond</p>   <p>1200 x 200 1400 x 200</p> | <p>Balcão Counter Mostrador Banque d'accueil</p>   <p>1600 x 319 x 670</p> | <p>* Vidro temperado 12mm * 12mm thick tempered glass top * Tablero en vidrio templado de 12mm * Plateau en verre tempéré 12mm</p>   <p>1400 x 800 x 720 1600 x 800 x 720 1800 x 800 x 720</p> | <p>Modulo Return Módulo de ala Retour</p>   <p>800 x 600 x 720 1000 x 600 x 720 1200 x 600 x 720 1400 x 600 x 720 1600 x 600 x 720</p> | <p>Modulo Return Módulo de ala Retour</p>   <p>800 x 600 x 720 1000 x 600 x 720 1200 x 600 x 720 1400 x 600 x 720 1600 x 600 x 720</p> | <p>Modulo Return Módulo de ala Retour</p>   <p>800 x 600 1000 x 600 1200 x 600 1400 x 600 1200 x 800 1400 x 800 1600 x 800</p> | <p>Mesa de reunião ou secretária Meeting table or desk Mesa de reunión o mesa de trabajo Table de réunion ou bureau</p>   <p>1600 x 1200 x 720 1800 x 1200 x 720 2000 x 1200 x 720 2200 x 1200 x 720</p> | <p>Mesa de reunião Meeting table Mesa de reunión Table de réunion</p>   <p>1600 x 1200 x 720 1800 x 1200 x 720 2000 x 1200 x 720 2200 x 1200 x 720</p> | <p>Mesa de reunião Meeting table Mesa de reunión Table de réunion</p>   <p>3200 x 1200 x 720 3600 x 1200 x 720</p> | <p>Mesa de reunião Meeting table Mesa de reunión Table de réunion</p>   <p>3200 x 1200 x 720 3600 x 1200 x 720</p> |
|--|---|---|---|---|---|---|---|---|---|

PERNAS E EXEMPLOS ESTRUTURAIS / LEGS AND STRUCTURAL PARTS / PIES Y EJEMPLOS ESTRUCTURALES / PIEDS ET EXEMPLES STRUCTURELS

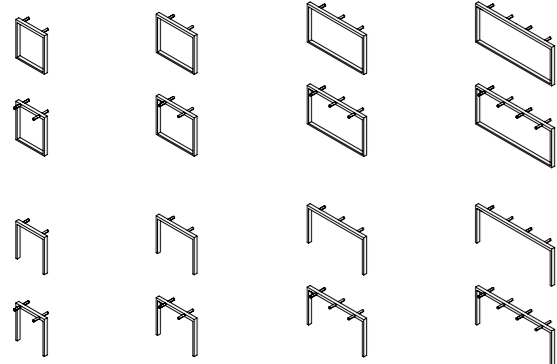
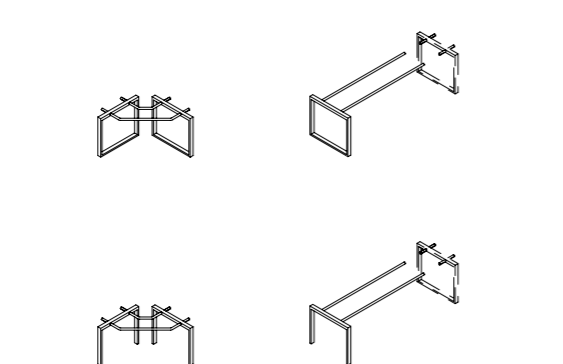
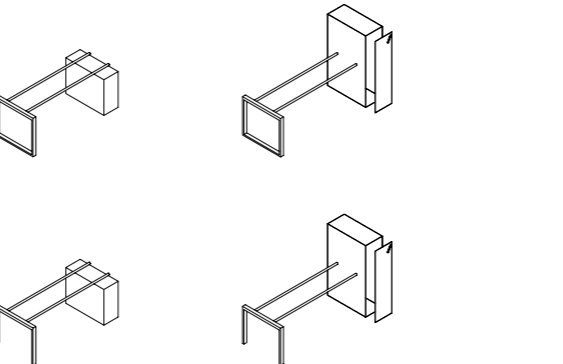
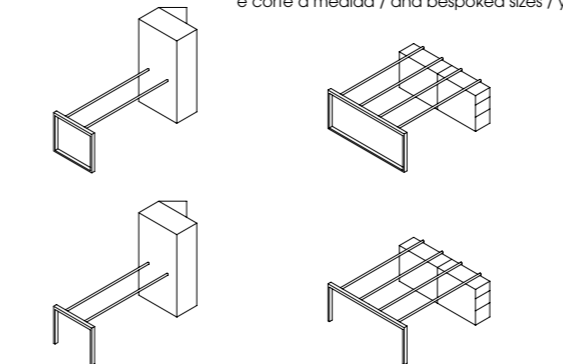
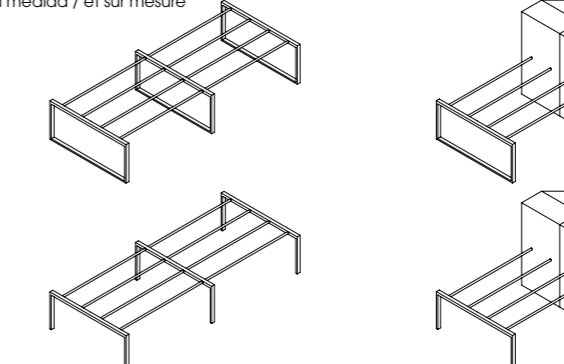
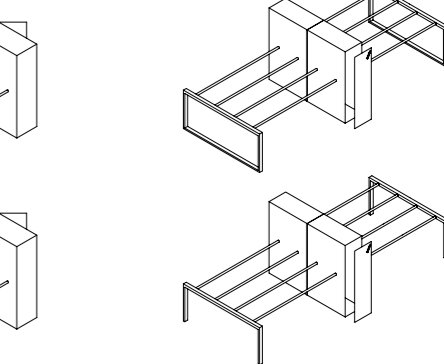
| | | | | | |
|---|--|---|---|---|---|
|  |  |  |  |  |  |
|---|--|---|---|---|---|

** e corte a medida / and bespoke sizes / y a medida / et sur mesure

ACABAMENTOS

Pernas das mesas: Branco, Preto, ou Metalizado. **Estrutura de tubo:** Branco, Preto, Metalizado o em Aço Inox. **Tampos das mesas:** Estratificado Branco, Preto. **Madeira:** Carvalho natural. **Vidro:** Transparente temperado 12mm. **Paneis separadores de mesas:** Estrutura interior metálica em tecido. **Zona de arquivo:** Blocos de gavetas metálicos pintados. Armários metálicos pintados

FINISHES

Legs: White, Black and Metallic grey. **Support bars:** White, Black, Metallic grey or Stainless steel. **Tops:** White or Black laminate. Natural oak veneer. Clear glass 12mm thick, toughened. **Fence screens:** Metal inner structure, fabric upholstered. **Storage units:** Metal pedestals. Metal storage cabinets.

ACABADOS

Pies mesas: Blanco, Negro, o Metalizado. **Tubos estructura:** Blanco, Negro, Metalizado o en Acero inoxidable. **Sobres mesa:** Estratificado Blanco, Negro. **Madera:** Roble natural. **Cristal:** Transparente templado 12 mm. **Paneles separadores mesa:** Estructura interior metálica tapizada en tela. **Contenedores:** Bloques de cajones metálicos pintados. Armarios metálicos pintados.

FINITIONS

Pieds des tables: Blanc, Noir ou Métallisé. **Traverses:** Blanc, Noir, Métallisé ou en Inox. **Plateau:** Stratifié Blanc, Noir. **Bois:** Chêne couleur naturel. **Verre:** Transparent tempéré 12mm. **Panneaux séparateurs:** Structure intérieure métallique revêtue de tissu. **Rangement:** Caissons métalliques peints. Armoires métalliques peintes.

A nossa produção evolui continuamente para satisfazer os interesses dos nossos clientes. A nossa fábrica reserva o direito de aplicar as modificações e/ou melhoramentos sem aviso prévio. Alteração de cores possível durante a impressão. A ocultação da marca Levira neste catalogo é penalizada por lei.

Our production is continually evolving to satisfy customer requirements. Modifications and/or improvements may occur without prior notice. Colors might change due to printing processes. The omission of the trademark Levira in this catalogue is punished by law.

Nuestra producción evoluciona continuamente para satisfacer los intereses de nuestros clientes. Nuestra fábrica se reserva el derecho de modificar sus productos sin previo aviso. Pueden haber cambios de color debidos a la impresión. La ocultación de la marca Levira de nuestro catálogo está penada por la ley.

Notre production évolue continuellement dans l'intérêt de la clientèle. Notre usine se réserve le droit d'apporter des modifications et / ou des améliorations sans préavis. Des changements de couleurs peuvent survenir au cours de l'impression. L'omission de la marque Levira dans ce catalogue sera possible de poursuite judiciaire en conformité avec la loi.

ZON
INTERNATIONAL

tel (+44) 20 8381 1222 email sales@zon.co.uk www.zon.co.uk

levira®



05MK0909